



Part of GE's Sensing &
Inspection Technologies business

RHE 11/RHE 12

Rheonik explosionproof transmitters

RHE 11 Features

- Stainless steel housing for wall/hook or sensor mounting
- Fully stainless steel version (316 SS optional available on request)
- Designed for use in hazardous areas
- ATEX/Ex II 2(1) G EEx d e [ia] IIC T5
- Two analog outputs (0/4 - 20/22 mA)
- One pulse/frequency output
- Available in all common supply voltages
- Multifunction (density, batch, brix, concentration...)
- Available with RS 422/485 or HART interface
- Enclosure rating: IP 66/Type 7X
- Power consumption: < 15 W
- Temperature range: -20°C to 60°C (-4°F to 140°F)



RHE 12 Features

- Compact version
- Designed for use in hazardous areas
- ATEX/Ex II 2 (1) G, EEx d [ia] IIC T6
- cCSAus Class 1, Div 1, Groups B, C, D
- One analog output (4 - 20 mA)
- One pulse output
- Power supply: 24 VDC
- HART interface
- Enclosure rating: IP 66/Type 7X
- Power consumption: about 7 W
- Temperature range: -20°C to 55°C (-4°F to 131°F)



imagination at work

RHE 11 Specifications

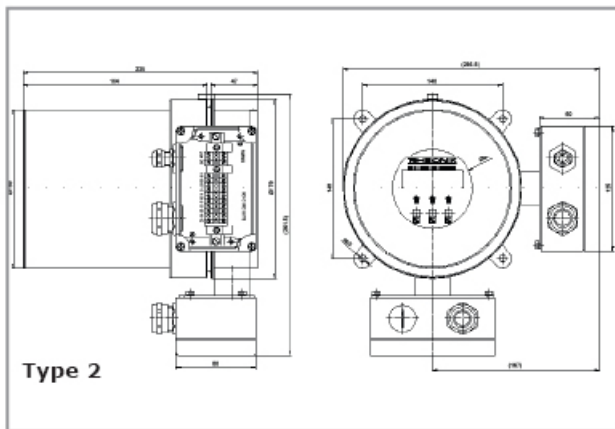
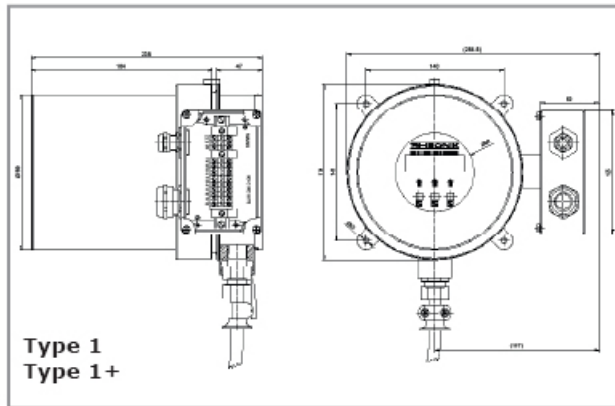

RHE 11

Housing	Explosion proof stainless steel(*)
Enclosure rating	IP 66/Type 7X
Dimensions	Diameter: 159 mm/6.26 in Height: 225 mm/8.86 in
Weight	~ 9 kg/19.84 lb
Op. temperature	-20°C to 60°C (-4°F to 140°F)
Display	Backlit LCD (16 characters, 2 lines)
Servicing	Via 3 photo sensors
Outputs(*)	2 analog outputs 1 frequency/pulse output 1 digital output (Lt, +/-, error...)
Power supply	230 VAC +/- 10% or 115 VAC +/- 10% or 24 VDC
Power and in/outputs	Via terminal box in Aluminum or stainless steel
RHM to RHE	2m or 10m integral cable or via built in termination box
Cable entries	2 x M25 x 1.5 others optional
Interface(**)	RS 422/485 - optional HART - optional

(*) Complete unit in SS 316 available.

(**) On request with 1 analog output and 1 digital input available in/outputs & interface via open collector optocouplers/galvanically isolated RS 422/RS 485.

RHE 12 Specifications

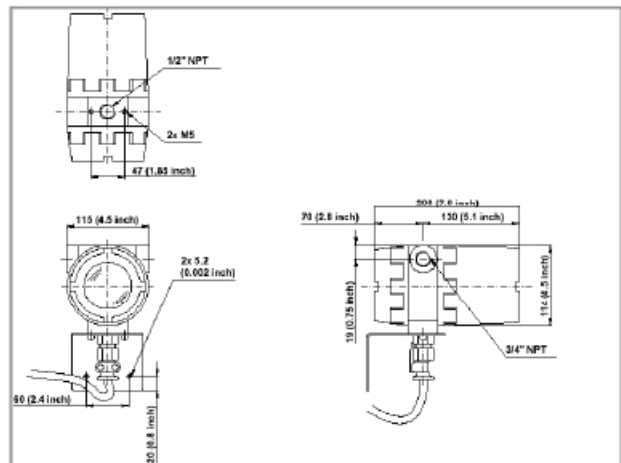

RHE 12

Housing	Explosion proof
Enclosure rating	IP 66/Type 7X
Dimensions	Diameter: 114 mm/4.5 in Height: 200 mm/7.9 in
Weight	~ 2 kg/4.40 lb
Op. temperature	-20°C to 55°C (-4°F to 131°F)
Display	Backlit LCD (16 characters, 2 lines)
Front Panel Controls	Via Two magnetic sensors
Outputs(**)	1 analog, 1 pulse output HART interface
Power supply	24 VDC(**)
Power and in/outputs	Via separated cable entries
RHM to RHE	Via 2m or 10m integral cable
Cable entries	¾ in NPT others optional

(**) In/outputs & interface via open collector optocouplers/galvanically isolated.
(**) (85-230 VAC optional with separate module - to be installed in safe area).

RHE 11 Ordering Information

RHE 11

Construction Type

- T1** 1 Terminal Box in Alu, for Power and I/O (Standard)
- supplied with 2 meters fixed connection cable (to sensor)
- T1+** 1 Terminal Box in Alu, for Power and I/O
- supplied with 10 meters fixed connection cable (to sensor)
- T2** 2 Terminal Boxes in Alu, for Signal, Power and I/O
- without connection cable/has to be extra ordered
- T3** 1 Terminal Box in Stainless Steel, for Power and I/O
- supplied with 2 meters fixed connection cable (to sensor)
- T4** 2 Terminal Boxes in Stainless Steel, Power and I/O
- without connection cable/has to be extra ordered

Power Supply

- A1** 230 VAC +/- 10%
- A2** 115 VAC +/- 10%
- D1** 24 VAC +/- 10%

I/O Interface Options

- IA** 2 x 4-20 mA, 1 pulse, 1 digital output (standard configuration)
- ID** 1 x 4-20 mA, pulse, 1 digital input, 1 digital output
- IO** Interface RS 485, 1 x 4-20 mA, pulse (not possible with HART)
- I1** Interface RS 422, 1 x 4-20 mA, pulse (not possible with HART)
- HH** Interface HART, 2 x 4-20 mA, pulse, 1 digital output
- HD** Interface HART, 1 x 4-20 mA, pulse, 1 digital input, 1 digital output
- IX** Customized

EEx Class

- E** Ex II 2 (1) G EEx d e [ia] IIC T5



I.e.: RHE 11 T1 A1 ID E

(*) Standard configuration includes:

- M25 x 1.5 cable entries (signal). Others (1/2 in NPT-F, 3/4 in NPT-F and M20 x 1.5) available on request.

RHE 12 Ordering Information

RHE 12

Construction Type

- T1** Pressure Safe Housing
- supplied with 2 meters fixed connection cable (to sensor)
- T2** Pressure Safe Housing
- supplied with 10 meters fixed connection cable (to sensor)

Power Supply

- D1** 24 VDC +/- 10%

Digital Interfaces

- HH** Interface HART

EEx Class

- E** Ex II 2 (1) G, EEx d [ia] IIC T6
- CS** cCSAus, Class 1, Div 1, Groups B, C, D



I.e.: RHE 12 T1 D1 HH E

(*) Standard configuration includes:

- 3/4 in cable entries (signal). Others (1/2 in NPT-F and 20 x 1,5) available on request.



www.gesensinginspection.com

920-487A